

Jensen®

loudspeakers

Tornado

Neodymium

N 12/100 TR 8Ω
Code ZJ06355
12" 100W

LOWS: Loose/Fat
MIDS: Subdued
HIGHS: Smooth
OVERDRIVE: Edgy

Sound Features:

Guitarist Description:

Crystal clear clean tones, accented by shimmering highs with each note sounding tight and well defined.

When presented with overdrive distortion, the notes remain well defined with lots of bite.

Specifications	
Nominal Diameter	307 mm (12")
Nominal Impedance	8 Ω
Rated Power AES ⁽¹⁾	100 W
Continuous Program Power ⁽²⁾	200 W
Sensitivity @ 1W/1m	98.5 dB
Voice Coil Diameter	50 mm
Voice Coil Winding Depth	10 mm
Magnetic Gap Depth	8 mm
Flux Density	1.20 T
Magnet Weight	200 g
Net Weight	2.0 kg

Thiele & Small Parameters ⁽³⁾			
Re	6.81 Ω	Fs	72.0 Hz
Qms	9.51	Mms	29.9 g
Qts	0.52	Bxl	12.93 Tm
Cms	163 μm/N	Sd	490.9 cm ²
Vas	55.9 l	Le (1kHz)	0.70 mH

Constructive Characteristics	
Magnet	Neodymium
Basket Material	Pressed Sheet Steel
Voice Coil Winding Material	Copper
Voice Coil Former Material	Nomex
Cone Material	Paper
Surround Treatment	Yes
Surround Material	Paper - Integrated
Dust Dome Material	Non Treated Cloth

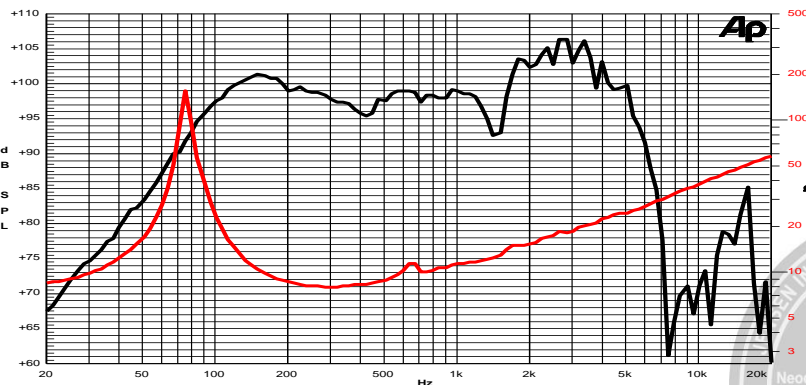
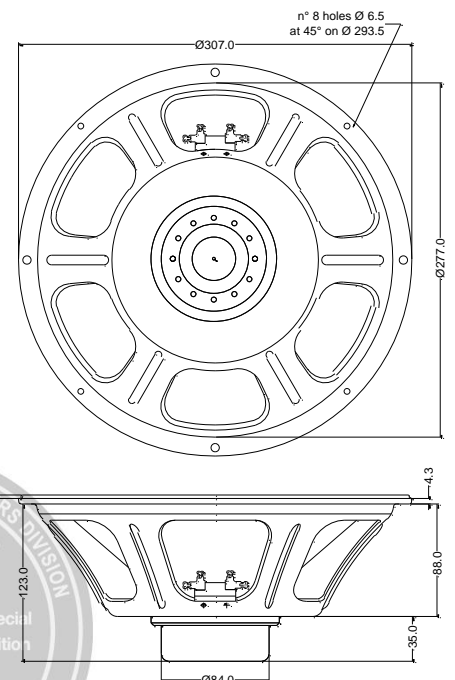

- Note:
- 1: Rated Power measured with 2 hours test with pink noise signal, 6dB crest factor, loudspeaker mounted on enclosure
 - 2: Power on Continuous Program is defined as 3 dB greater than the Rated Power
 - 3: Thiele & Small parameters measured with laser system without preconditioning test
 - 4: Drawing dimensions: mm
 - 5: The notch around 400Hz on the frequency response is typical of the measurement on IEC baffle

